

LETTER	DESCRIPTION	REVISION	DATE	REV.NO
(A)	Bore hole diameter tolerance is changed. Before +1 Now +0.2	Drawing is changed.	09.09.04	1

AA-SECTION

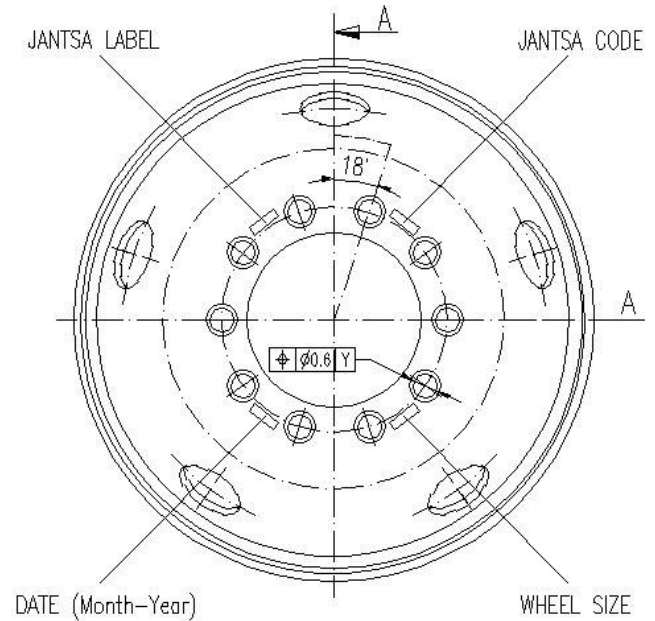
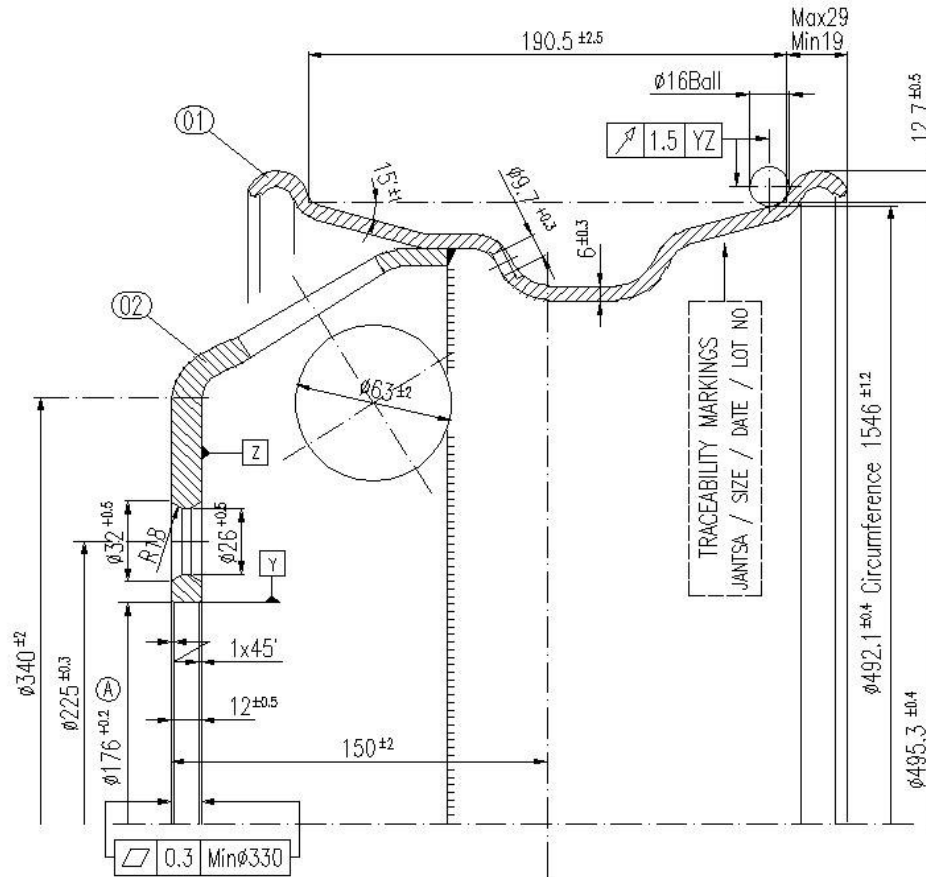

MON.NO	PCS	PART NAME	MATERIAL	CUTTING MEASURE	WEIGHT
02	1	DISC	ERD 3944 / St 44-2	-	-
01	1	RIM	ERD 3936 / St 37-2	-	-

FINISHING TOLERANCES : All surfaces marked with \surd are to be machined unless otherwise indicated general machining tolerances:

DISTRIBUTION		1) ANGULAR TOLERANCE = $\pm 0' 10'$				
Technical Department	1	2) DIMENSIONAL TOLERANCE (mm)				
Production Department	1		Up to 6	6 to 30	30 to 100	100 to 300
Quality Assurance Dept.	1		Diameter	± 0.05	± 0.1	± 0.15
INVESTMENT NO		Length	± 0.1	± 0.2	± 0.3	± 0.5
PAGE NO						

DO NOT ADJUST THE DIMENSION FROM THE DRAWING			
NAME	SIGNATURE	DATE	
DRAWN BY	M.KARADELI	15.10.98	
CHECKED	M.KARADELI	15.10.98	
APPROVED	C.GÜLERYÜZ	15.10.98	
SCALE	Item Name:		
	19.5x7.50		

JantSa
 Wheel Industry & Trade Inc.Co.
 Phone : 0 256 259 11 25
 Fax : 0 256 259 11 24
 AYDIN / TURKEY

DRAWING NO
750192

Fig. 19.5x7.50 (Specification of 19.5x7.50) and L.P. 750192